

**LITTLE LEAGUE
INFIELD SKIN TARP**
Specifications and Layout

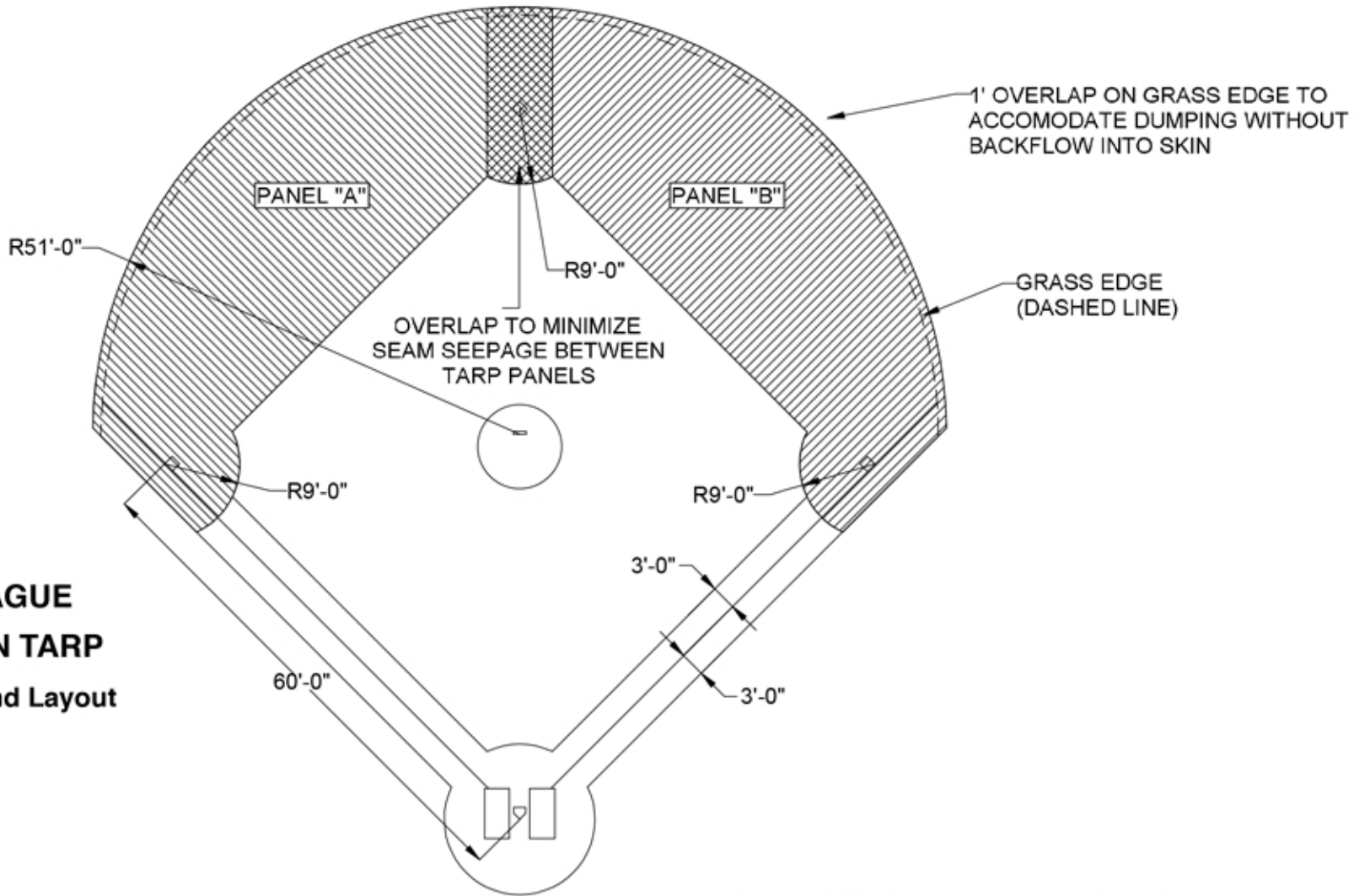

MATERIAL:
6-OZ/SQ YD SILVER/WHITE WOVEN POLYETHYLENE
(APPROXIMATELY 80 LBS/PANEL)

EACH SET INCLUDES (2) OVERLAPPING PANELS WITH A 1' OVERLAP ONTO THE GRASS EDGE OF THE BACK RADIUS

ALL EDGES ARE HEMMED AND GROMMETED AT 5' INTERVALS WITH HANDLES SEWN APPROXIMATELY EVERY 10'

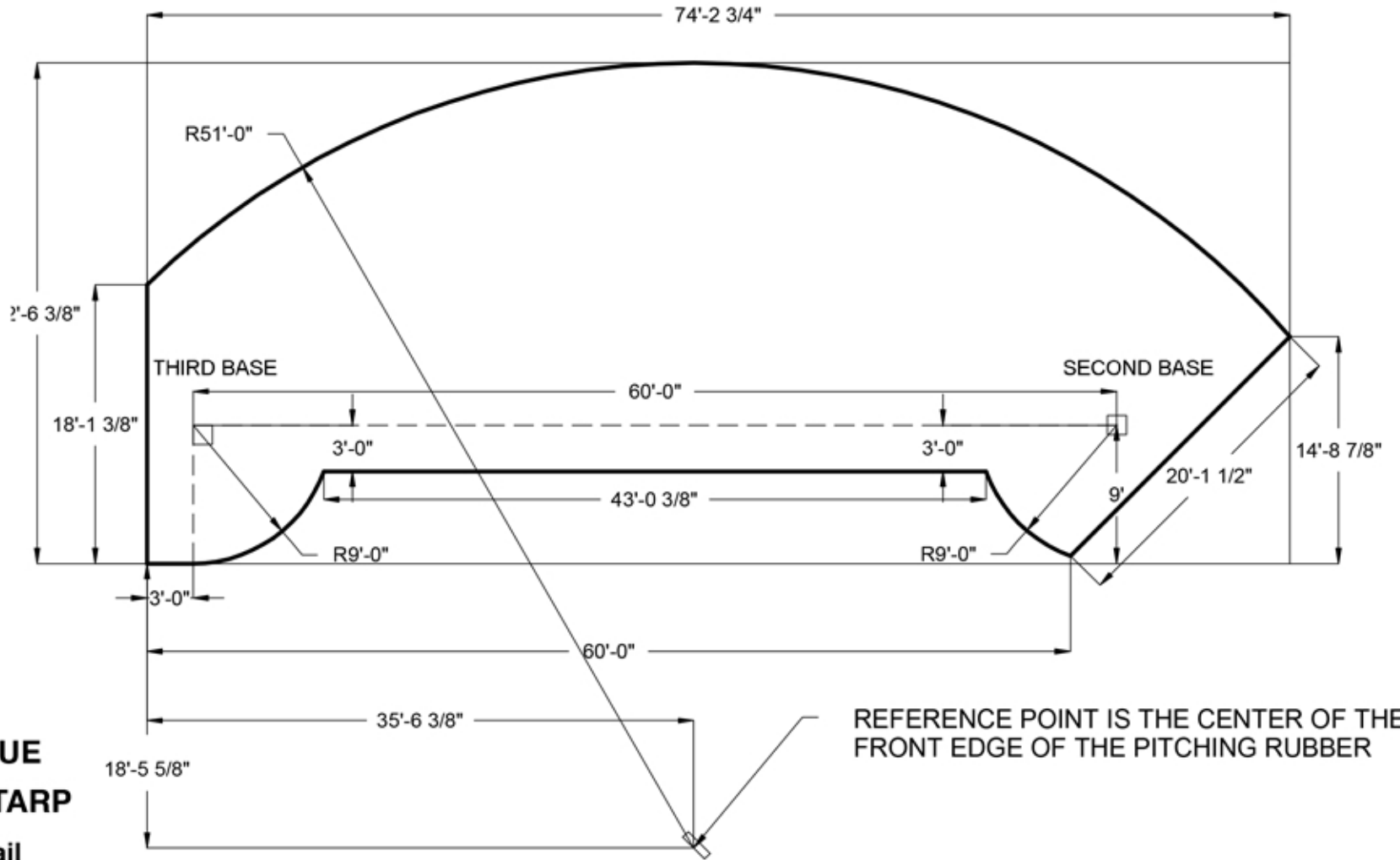

**LITTLE LEAGUE
 INFIELD SKIN TARP**
 Panel "A" Detail

DIMENSIONS SHOWN ARE TO 1/8" PRECISION.
 ACTUAL PRODUCTION TOLERANCE IS +/- 3 TO 4 INCHES.

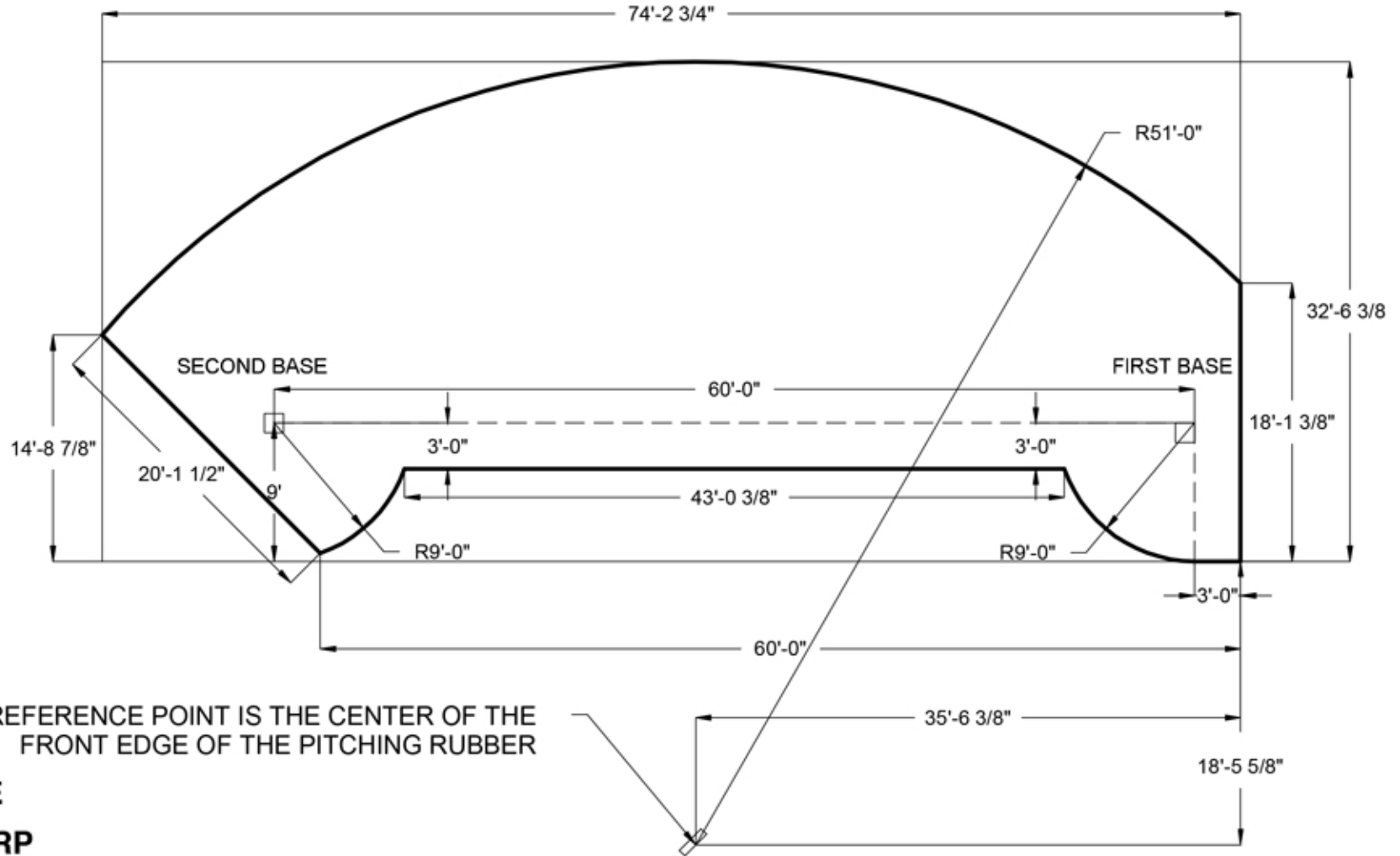

**LITTLE LEAGUE
INFIELD SKIN TARP**

Panel "B" Detail

DIMENSIONS SHOWN ARE TO 1/8" PRECISION.
ACTUAL PRODUCTION TOLERANCE IS +/- 3 TO 4 INCHES.